

märklin
Z

Modell der Elektrolok BR 120

mini-club

88179

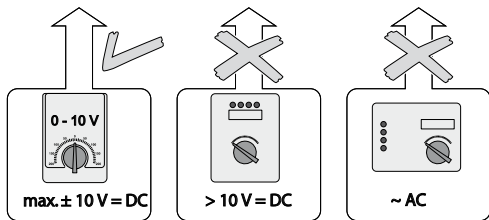

67011
67020 + 67030
67201
67271

Sicherheitshinweise

- **ACHTUNG!** Funktionsbedingte scharfe Kanten und Spitzen.
- Das verwendete Gleisanschlusskabel darf maximal 2 Meter lang sein.

Safety Notes

- **WARNING!** Sharp edges and points required for operation.
- The wire used for feeder connections to the track may be a maximum of 2 meters / 78 inches long.

Remarques importantes sur la sécurité

- **ATTENTION !** Pointes et bords coupants lors du fonctionnement du produit.
- Le câble de raccordement à la voie utilisé ne doit en aucun cas dépasser deux mètres.

Veiligheidsvoorschriften

- **OPGEPAST!** Functionele scherpe kanten en punten.
- De gebruikte aansluitkabel mag maximaal 2 meter lang zijn.

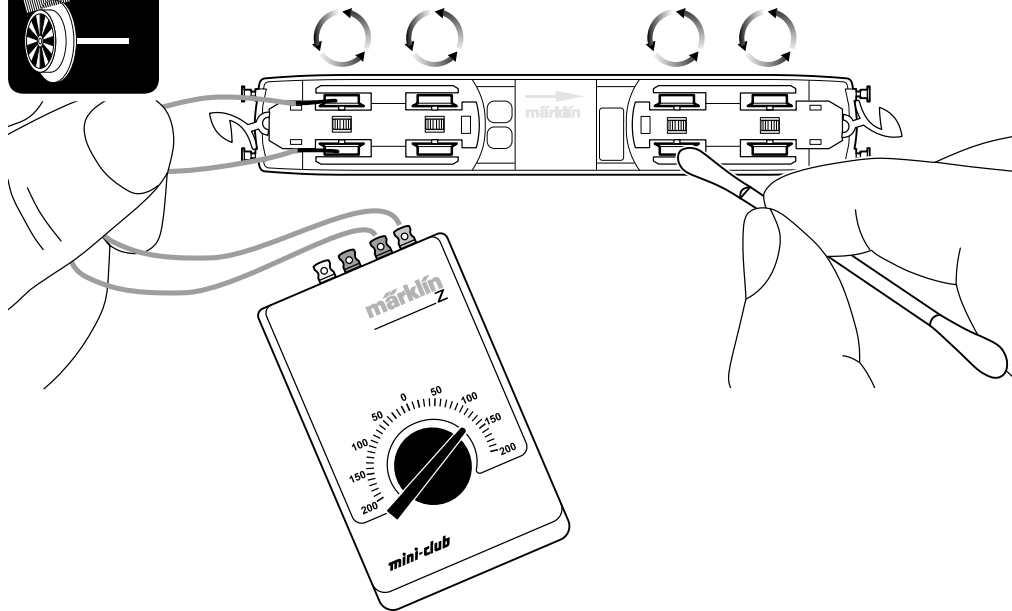
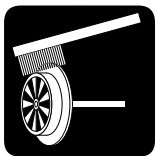

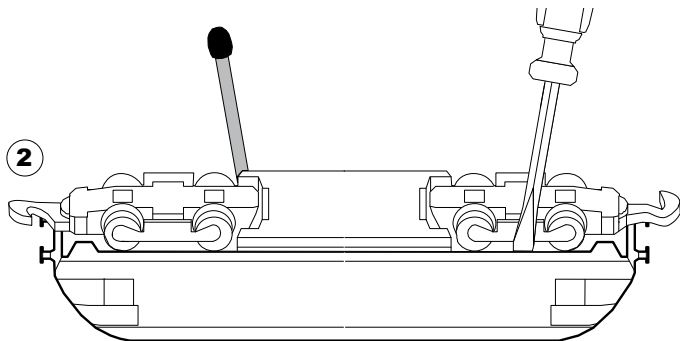
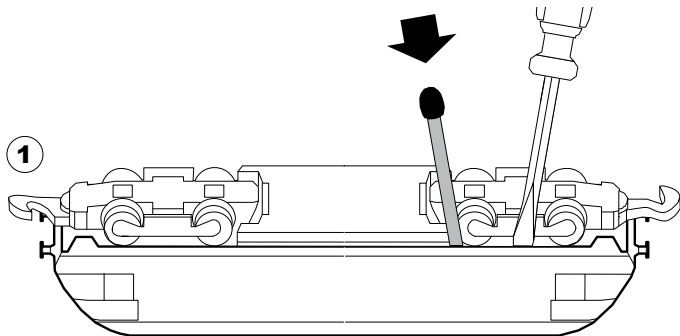

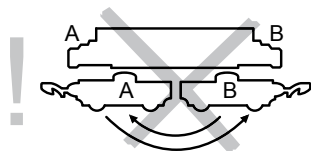
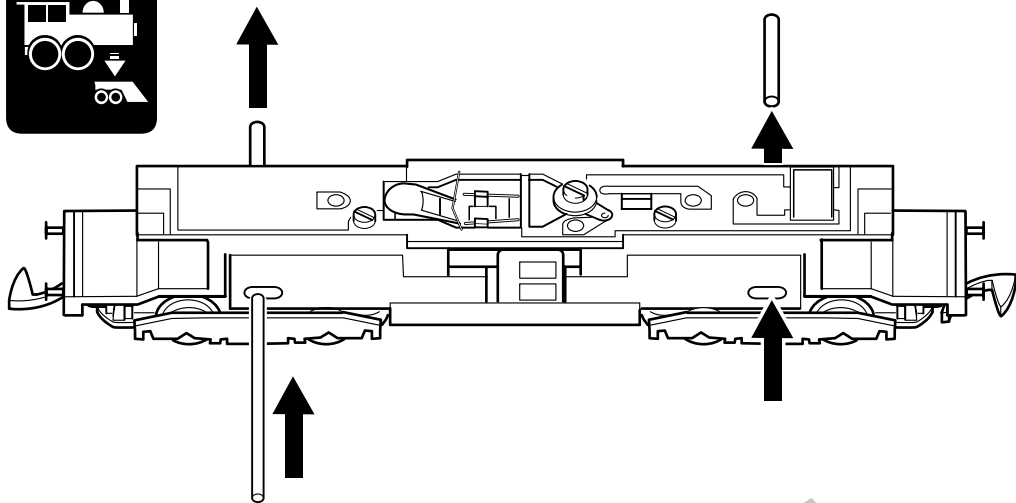

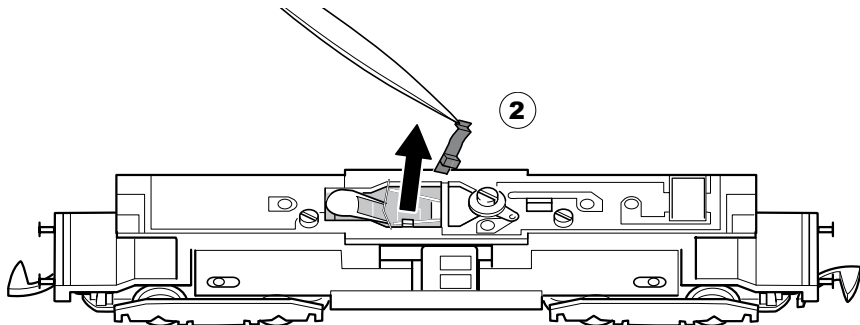
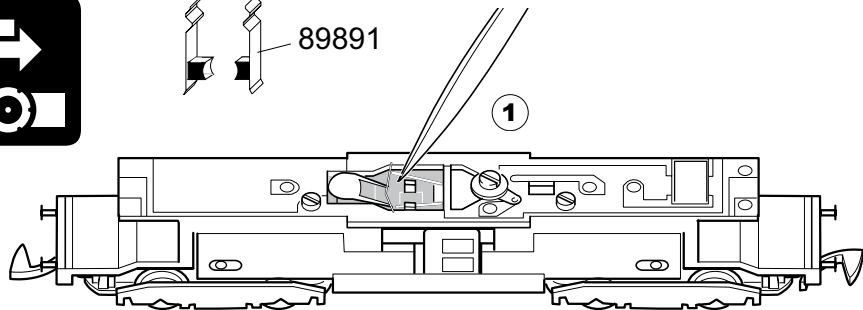
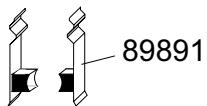
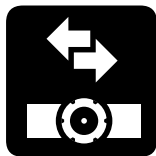

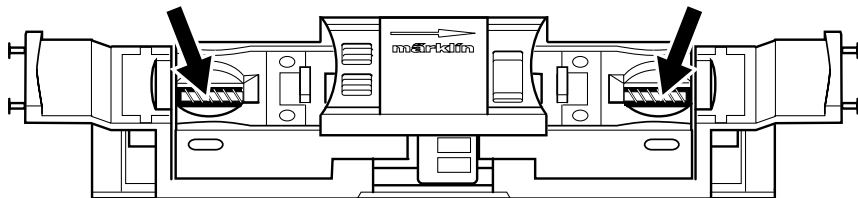
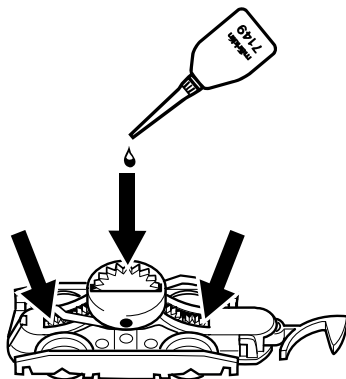
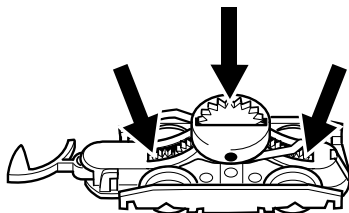

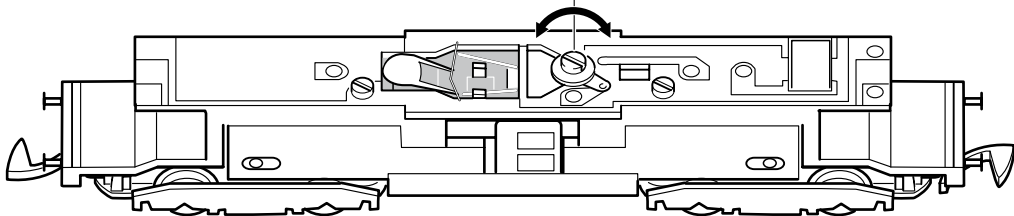
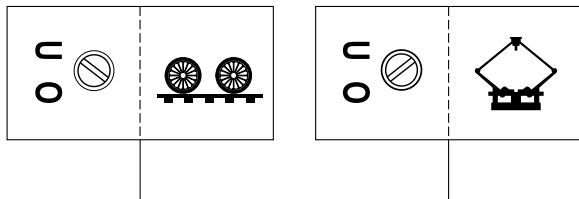
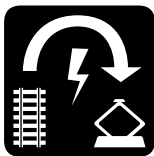

Bei Oberleitungsbetrieb Pfeil beachten!

To operate the catenary system follow the direction indicated by the arrow.

Pour utilisation de la caténaire tenir compte de la flèche.

Bij gebruik van bovenleiding op pijl letten!

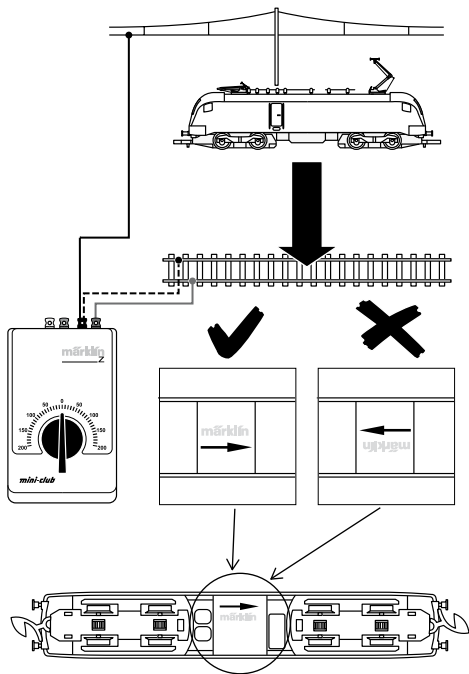

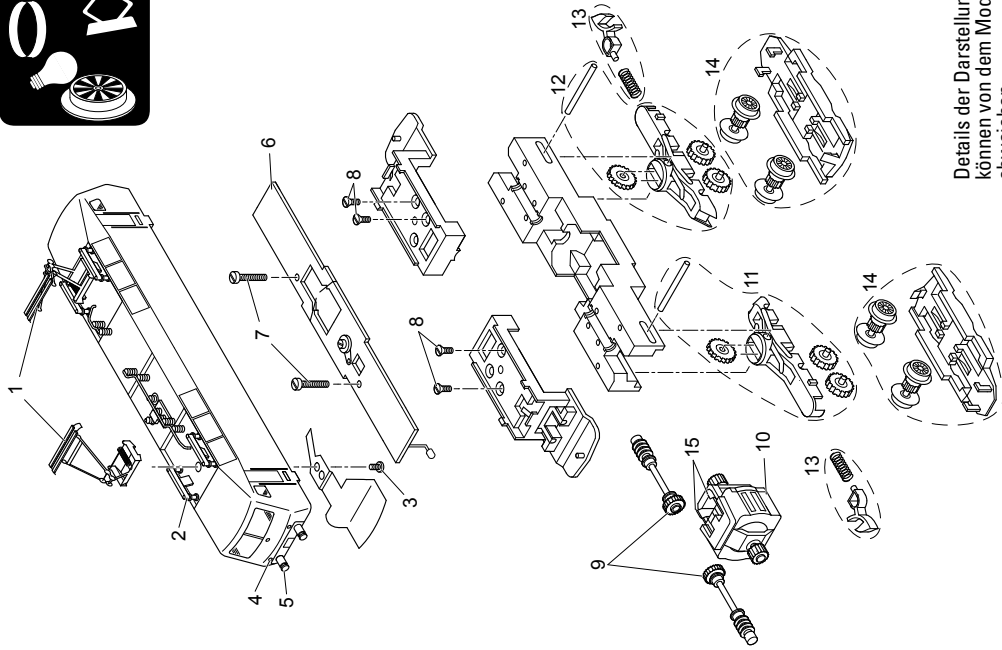

Details der Darstellung
können von dem Modell
abweichen.

1	Einholmstromabnehmer	E265 370
2	Trägerisolation	E163 969
3	Schraube	E785 150
4	Lichtkörper	E265 310
5	Puffer	E167 989
6	Leiterplatte	E193 310
7	Schraube	E785 190
8	Schraube	E785 550
9	Antriebswelle	E265 250
10	Motor	E211 903
11	Getriebegehäuse vorn	E248 297
12	Getriebegehäuse hinten	E248 301
13	Kupplung	E166 264
14	Radsätze/Blende	E248 303
15	Bürstenpaar	89 891

Hinweis: Einige Teile werden nur ohne oder mit anderer Farbgebung angeboten.

Teile, die hier nicht aufgeführt sind, können nur im Rahmen einer Reparatur im Märklin-Reparatur-Service repariert werden.

Due to different legal requirements regarding electro-magnetic compatibility, this item may be used in the USA only after separate certification for FCC compliance and an adjustment if necessary.

Use in the USA without this certification is not permitted and absolves us of any liability. If you should want such certification to be done, please contact us – also due to the additional costs incurred for this.

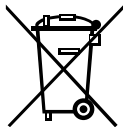

Gebr. Märklin & Cie. GmbH
Stuttgarter Str. 55 - 57
73033 Göppingen
Germany
www.maerklin.com

www.maerklin.com/en/imprint.html

247731/0215/Sm1Ef
Änderungen vorbehalten
© Gebr. Märklin & Cie. GmbH